

Reference Design using the HC5503PRC SLIC and the Texas Instruments TCM38C17 Quad Combo

The network requirements of many countries require the analog subscriber line circuit (SLIC) to terminate the subscriber line with an impedance for voiceband frequencies which is complex, rather than resistive (e.g., 600Ω). This requires that the physical resistance that is situated between the SLIC and the subscriber line, comprised of protection and/or sensing resistors, and the output resistance of the SLIC itself, be adapted to present an impedance to the subscriber line that varies with frequency. This is accomplished using feedback around the SLIC.

The purpose of this application note is to show a means of accomplishing this task for the HC5503PRC and Texas Instruments TCM38C17 Quad Combo.

Discussed in this application note are the following:

- 2-wire 600Ω impedance matching
- 2-wire complex impedance matching
- Receive gain (4-wire to 2-wire) and transmit gain (2-wire to 4-wire) calculations
- Transhybrid balance calculations
- Reference design for 600Ω 2-wire load
- Reference design for China complex 2-wire load

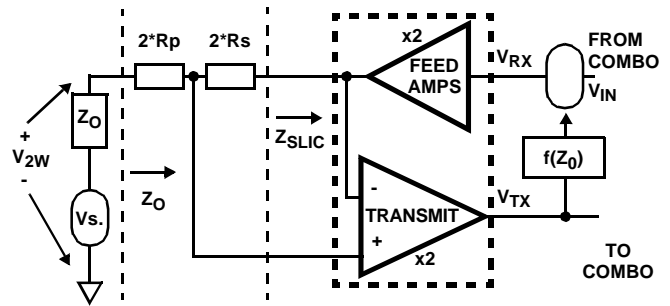

FIGURE 1. IMPEDANCE MATCHING BLOCK DIAGRAM

Impedance Matching

Impedance matching of the HC5503PRC to the subscriber load is important for optimization of 2 wire return loss, which in turn cuts down on echoes in the end to end voice communication path. It is also important for maintaining voice signal levels on long loops. Consider the equivalent circuit shown in Figure 1.

The circuitry inside the dotted box is representative of the SLIC feed and transmit amplifiers. The feed and transmit amplifiers pass the voice signals in the receive and transmit directions respectively. Without the feedback block $f(Z_0)$, the termination resistance at V_{2W} would equal the two protection resistors (R_P) and the two sense resistors (R_S), as the feed amplifiers present a very low output impedance to the subscriber line. The desired termination impedance at V_{2W} is Z_0 . The feedback block $f(Z_0)$ matches the SLIC's output impedance (Z_{SLIC}) plus the two protection resistors (R_P) and the two sense resistors (R_S) to the load (Z_0).

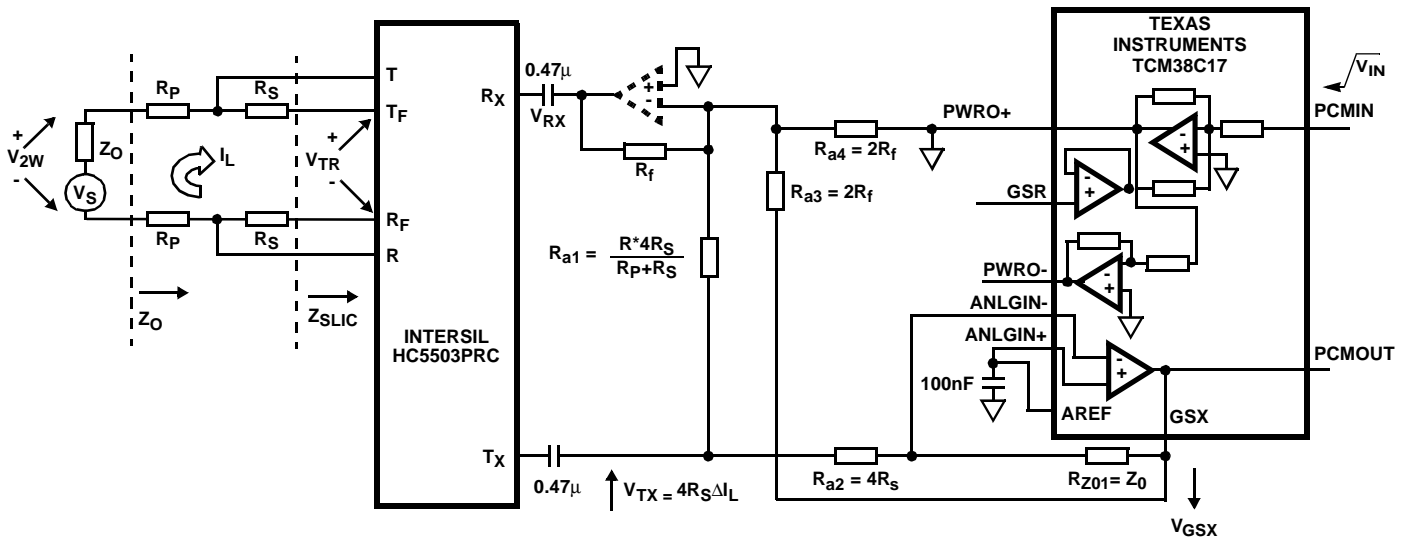

FIGURE 2. IMPEDANCE MATCHING

Impedance matching of the HC5503PRC is accomplished by making the SLIC's impedance (Z_{SLIC} , Figure 2) equal to the desired terminating impedance Z_0 , minus the value of the protection and sense resistors. The desired impedance at the input to the SLIC is given in Equation 1.

$$Z_{SLIC} = Z_0 - 2 \times R_P - 2 \times R_S \quad (\text{EQ. 1})$$

The AC loop current required to satisfy this condition is given in Equation 2.

$$\Delta I_L = \frac{V_{TR}}{(Z_0 - 2 \times R_P - 2 \times R_S)} \text{ at matching} \quad (\text{EQ. 2})$$

The current calculated in Equation 2 is used as feedback to match the impedance of the SLIC and both protection and sense resistors to the load Z_0 .

The output voltage of the SLIC (V_{TX}) is defined by design and given in Equation 3.

$$V_{TX} = 4R_S \Delta I_L \quad (\text{EQ. 3})$$

Substituting for ΔI_L from Equation 2 into Equation 3 results in the voltage at the V_{TX} output that will be used to generate the required feedback.

$$V_{TX} = \frac{4R_S \times V_{TR}}{(Z_0 - 2 \times R_P - 2 \times R_S)} \quad (\text{EQ. 4})$$

By design, V_{TR} is equal to 2 times the voltage at the receive input (R_X) Figure 2.

$$V_{TR} = 2 \times V_{RX} \quad (\text{EQ. 5})$$

Substituting Equation 5 into Equation 4.

$$V_{TX} = \frac{4R_S \times 2 \times V_{RX}}{(Z_0 - 2 \times R_P - 2 \times R_S)} \quad (\text{EQ. 6})$$

Solving Equation 6 for the voltage at V_{RX} as a function of V_{TX} (when matching the Z_{SLIC} , the two protection resistors (R_P) and the two sense resistors (R_S) to the load Z_0) is given in Equation 7.

$$\frac{V_{RX}}{V_{TX}} = \frac{(Z_0 - 2 \times R_P - 2 \times R_S)}{8 \times R_S} \quad (\text{EQ. 7})$$

Equation 7 is the gain of the feedback circuit (output/input = V_{RX}/V_{TX}) used to match the impedance of the SLIC and both protection and sense resistors. Note: In Equation 7 it seemed logical to simplify the numerator by trying to combine Z_0 and the two subsequent terms together. In practice however, the impedance of the network you want to match (Z_0) cannot easily have $2 \times R_P$ and $2 \times R_S$ subtracted from it since the sum of these resistors is often larger than the value of the series resistance of the complex network.

Equation 7 is therefore rewritten in Equation 8.

$$\frac{V_{RX}}{V_{TX}} = \frac{Z_0}{8 \times R_S} - \frac{2 \times (R_P + R_S)}{8 \times R_S} \quad (\text{EQ. 8})$$

Analysis of Equation 8 yields a 2 op amp feedback network. The first term has Z_0 and no phase inversion. This requires the path to flow through 2 op amps and makes the matching of different complex loads easy. (i.e., can set Z_0 in feedback network equal to the Z_0 you want to match). The second term has a phase inversion and requires only one op amp in the feedback path.

Figure 2 shows the circuit required to achieve matching of the SLIC's impedance to the load Z_0 . The voltage at V_{RX} is a function of V_{TX} , V_{GSX} ($V_{TX}R_{ZO1}/R_{a2}$) and V_{IN} .

The voltage at V_{RX} is determined via superposition. The circuit equation for the feedback network is given in Equation 9.

$$V_{RX} = -V_{TX} \frac{R_f}{R_{a1}} + \frac{V_{TX} R_{ZO1} R_f}{R_{a2} R_{a3}} - \frac{V_{IN} R_f}{R_{a4}} \quad (\text{EQ. 9})$$

For impedance matching of the two wire side, we set V_{IN} equal to zero. This reduces Equation 9 to that shown in Equation 10.

$$V_{RX} = -V_{TX} \frac{R_f}{R_{a1}} + \frac{V_{TX} R_{ZO1} R_f}{R_{a2} R_{a3}} \quad (\text{EQ. 10})$$

To achieve the desired matching of the circuit to the line impedance Z_0 , we set our design Equation 8 equal to our circuit Equation 10. By inspection of the correct phase in Equations 8 and 10, we have Equations 11 and 12.

$$\frac{Z_0}{8 \times R_S} = \frac{R_{ZO1} R_f}{R_{a2} R_{a3}} \quad (\text{EQ. 11})$$

$$\frac{2 \times (R_P + R_S)}{8 \times R_S} = \frac{R_f}{R_{a1}} \quad (\text{EQ. 12})$$

Given: $R_f = R$, $R_{a3} = 2R$, $R_{ZO1} = Z_0$ Note: by making $R_{a3} = 2R_f$, the value of R_{a2} becomes $4R_S$ (Equation 13). This results in the 2-wire to 4-wire gain being equal to 1 (Equation 24 and Equation 25)

From Equation 11.

$$R_{a2} = 4R_S \quad (\text{EQ. 13})$$

From Equation 12.

$$R_{a1} = \frac{R \times 4R_S}{R_P + R_S} \quad (\text{EQ. 14})$$

Receive Gain (V_{IN} to V_{2W})

4-wire to 2-wire gain is equal to the V_{2W} divided by the input voltage V_{IN} , reference Figure 3. The gain through the TCM38C17 is equal to one ($V_{IN} = V_{PCMIN} = V_{PWRO+}$).

$$A_{4W-2W} = \frac{V_{2W}}{V_{IN}} \quad (\text{EQ. 15})$$

The 2-wire voltage V_{2W} is determined by a loop equation and is given in Equation 16.

$$V_{2W} = (2R_P + 2R_S)\Delta I_L + V_{TR} \quad (\text{EQ. 16})$$

Combining Equation 5 and Equation 9, gives an expression for V_{TR} in terms of V_{RX} , as shown in Equation 17.

$$V_{TR} = 2V_{RX} = 2\left(-V_{TX}\frac{R_f}{R_{a1}} + \frac{V_{TX}R_{Z01}R_f}{R_{a2}R_{a3}} - \frac{V_{IN}R_f}{R_{a4}}\right) \quad (\text{EQ. 17})$$

The voltage at V_{TR} is therefore a function of V_{TX} and V_{IN} . Note: contribution from V_{GSX} (middle term in Equation 17) is zero due to the transhybrid circuit, reference section titled "Transhybrid Balance G(4-4)".

This reduces Equation 17 to Equation 18.

$$V_{TR} = 2V_{RX} = -2\left(V_{TX}\frac{R_f}{R_{a1}} + \frac{V_{IN}R_f}{R_{a4}}\right) \quad (\text{EQ. 18})$$

Substituting $4R_S\Delta I_L$ (Equation 3) for V_{TX} in Equation 18 and combining this with Equation 16, results in an equation for V_{2W} in terms of: ΔI_L , the external resistors and the input voltage V_{IN} (Equation 19).

$$V_{2W} = (2R_P + 2R_S)\Delta I_L - 8R_S\Delta I_L\frac{R_f}{R_{a1}} - 2\frac{V_{IN}R_f}{R_{a4}} \quad (\text{EQ. 19})$$

Ohms law defines ΔI_L as being equal to $-V_{2W}/Z_O$. Substituting $-V_{2W}/Z_O$ for ΔI_L in Equation 19 gives Equation 20.

$$V_{2W} = -(2R_P + 2R_S)\frac{V_{2W}}{Z_O} + 8R_S\frac{V_{2W}}{Z_O}\frac{R_f}{R_{a1}} - 2\frac{V_{IN}R_f}{R_{a4}} \quad (\text{EQ. 20})$$

Equation 20 can be rearranged to solve for the 4-wire to 2-wire gain V_{2W}/V_{IN} , as shown in Equation 21.

$$A_{4W-2W} = \frac{V_{2W}}{V_{IN}} = -\left(\frac{2R_f}{R_{a4}}\right) \times \frac{R_{a1}Z_O}{R_{a1}(2R_P + 2R_S) + R_{a1}Z_O - 8R_S R_f} \quad (\text{EQ. 21})$$

Given: $R_f = 100k\Omega$, $R_{a4} = 200k\Omega$, $R_{a1} = 267k\Omega$, $Z_O = 600\Omega$, $R_S = 100\Omega$, $R_P = 50\Omega$.

Note: by making R_{a4} equal to $2R_f$ the 4-wire to 2-wire gain becomes -1.

Transmit Gain across HC5503PRC (V_{2W} to V_{TX})

The output voltage of the SLIC (V_{TX}) was defined in Equation 3 as being equal to $4R_S\Delta I_L$. ΔI_L is equal to twice the input voltage ($2V_{RX}$) divided by the total loop resistance as shown in Figure 4. If the load impedance is 600Ω , then the gain across the HC5503PRC is 2/3 the input voltage V_{RX} . Likewise, if the load impedance is 811Ω , (next example with a complex load) then the gain across the HC5503PRC is $400/811$ times the input voltage V_{RX} .

Transmit Gain (V_{2W} to V_{GSX})

2-wire to 4-wire gain is equal to the V_{GSX} voltage divided by the 2-wire voltage V_{2W} , reference Figure 3.

$$A_{2W-4W} = \frac{V_{GSX}}{V_{2W}} \quad (\text{EQ. 22})$$

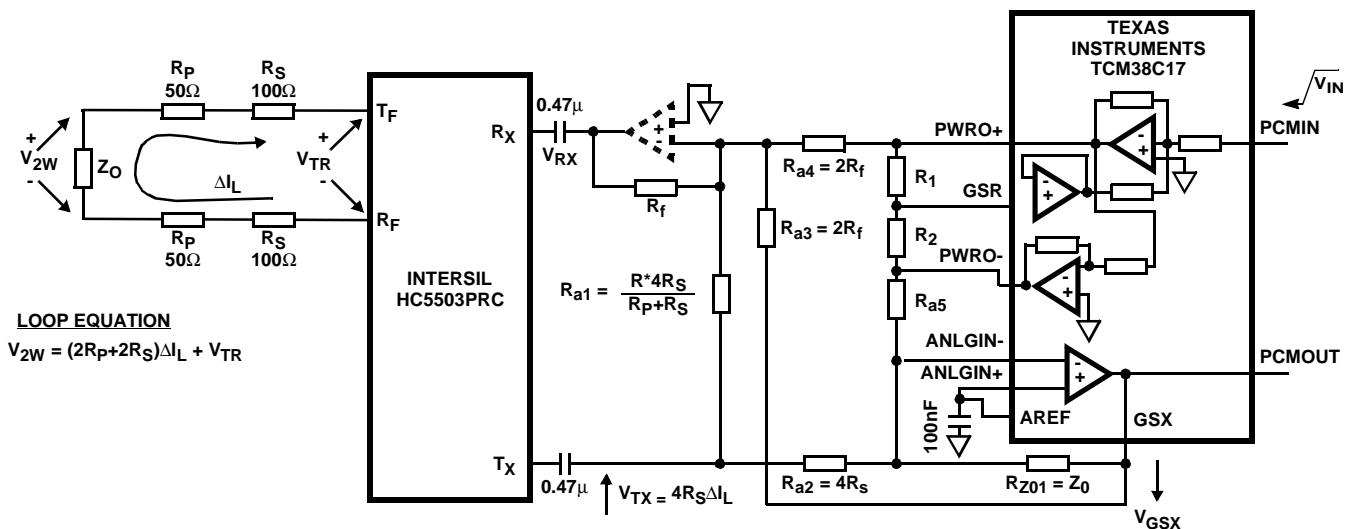

FIGURE 3. RECEIVE GAIN G(4-2), TRANSMIT GAIN (2-4) AND TRANSHYBRID BALANCE (FEEDBACK CIRCUIT ONLY)

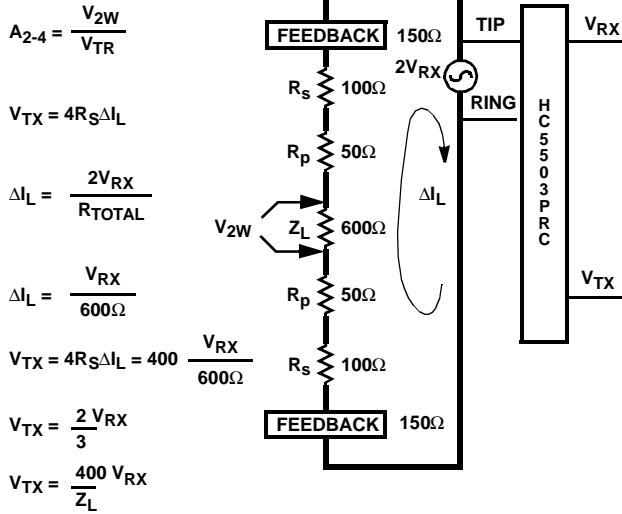

FIGURE 4. TRANSMIT GAIN ACROSS HC5503PRC (V_{2W} to V_{TX})

V_{GSX} is only a function of V_{TX} and the feedback resistors R_{a2} and R_{Z01} . Equation 23. This is because V_{IN} is considered ground for this analysis, thereby effectively grounding the V_{PWRO-} input.

$$V_{GSX} = -V_{TX} \frac{R_{Z01}}{R_{a2}} \quad (\text{EQ. 23})$$

Substituting Equation 3 for V_{TX} and ΔI_L for $-V_{2W}/Z_O$ into Equation 23, V_{GSX} equals:

$$V_{GSX} = 4R_S \frac{V_{2W}}{Z_O} \left(\frac{R_{Z01}}{R_{a2}} \right) \quad (\text{EQ. 24})$$

Z_O is equal to R_{Z01} (actual values of R_{Z01} and R_{a2} were multiplied by 1000 to reduce loading effects on the op amps). Simplifying Equation 24 and assuming $R_{a2} = 4R_S$ from Equation 13 results in Equation 25.

$$A_{2W-4W} = \frac{V_{GSX}}{V_{2W}} = \left(\frac{4R_S}{4R_S} \right) = 1 \quad (\text{EQ. 25})$$

The transmit gain 2-wire to 4-wire is equal to one.

Transhybrid Balance G(4-4)

Transhybrid balance is a measure of how well the input signal is canceled (that being received by the SLIC) from the transmit signal (that being transmitted from the SLIC to the CODEC). Without this function, voice communication would be difficult because of the echo.

The signals at V_{PWRO+} and V_{TX} (Figure 3) are in phase. Transhybrid balance is achieved by summing two signals that are equal in magnitude and opposite in phase into the GSX amplifier. The TCM38C17 provides a signal that is equal in magnitude and opposite in phase from the $PWRO+$ signal. That signal is present on the $PWRO-$ pin.

Transhybrid balance is achieved by summing the $PWRO-$ signal with the output signal from the HC5503PRC when the proper gain adjustments are made to match V_{PWRO-} and V_{TX} magnitudes.

For discussion purpose, the GSX amplifier is redrawn with the external resistors in Figure 5.

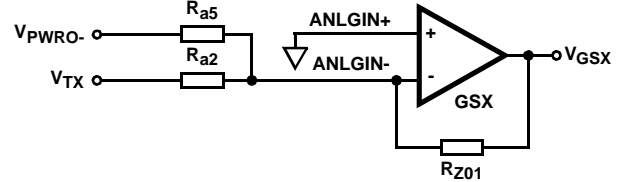

FIGURE 5. TRANSHYBRID BALANCE CIRCUIT

The gain through the GSX amplifier from V_{TX} is set by resistors R_{a2} and R_{Z01} . Both resistors (R_{a2} and R_{Z01}) are used in the feedback loop to match the two wire impedance, and thus set. The gain through the GSX amplifier from $PWRO-$ is set by resistors R_{a5} and R_{Z01} . Matching of the magnitudes for transhybrid balance will be accomplished using resistor R_{a5} .

Using superposition for both inputs to the GSX amplifier and setting both gains equal to each other yields Equation 26.

$$V_{TX} \left(\frac{R_{Z01}}{R_{a2}} \right) = V_{PWRO-} \left(\frac{R_{Z01}}{R_{a5}} \right) \quad (\text{EQ. 26})$$

Cancelling out R_{Z01} , setting V_{TX} equal to $400/Z_L$ times (V_{PWRO-}) and rearranging to solve for R_{a5} results in Equation 27.

$$R_{a5} = V_{PWRO-} \left(\frac{R_{a2}}{V_{TX}} \right) = \frac{R_{a2} Z_L}{400} \quad (\text{EQ. 27})$$

The values of R_{a2} , R_{a5} , and R_{Z01} should be scaled by 1000 to minimize loading of the GSX amplifier (Figure 5).

Reference Design of the HC5503PRC and the TCM38C17 With a 600Ω Load Impedance

The design criteria is as follows:

- 4-wire to 2-wire gain (PCMIN to V_{2W}) equal 0dB
- 2-wire to 4-wire gain (V_{2W} to PCMOUT) equal 0dB
- Two Wire Return Loss greater than -30dB (200Hz to 4kHz)
- $R_p = 50$, $R_s = 100$

Figure 6 gives the reference design using the Intersil HC5503PRC SLIC and the Texas Instruments TCM38C17 Quad Combo. Also shown in Figure 5 are the voltage levels at specific points in the circuit. These voltages will be used to adjust the gains of the network.

Impedance Matching

For impedance matching of the 2-wire side we set the input voltage at PCMIN equal to zero. This effectively grounds the PWRO- input of the GSX amplifier. To determine the value of R_{a2} to achieve a 2-wire to 4-wire gain (V_{2W} to PCMOUT) of 0dB we use Equation 24, repeated here for convenience in Equation 28.

$$V_{GSX} = 4R_S \frac{V_{2W}}{Z_0} \left(\frac{R_{ZO1}}{R_{a2}} \right) \quad (\text{EQ. 28})$$

Substituting the required voltage levels (Figure 6) for V_{GSX} (0.7745) and V_{2W} (0.7745) and rearranging to solve for R_{a2} results in Equation 29. Where: $V_{GSX} / V_{2W} = 1.0$, and $Z_0 = R_{ZO1}$:

$$R_{a2} = \frac{400}{1.0} = 400 \quad (\text{EQ. 29})$$

The value of R_{a2} needs to be scaled by 1000 to minimize the effects of loading on the GSX amplifier. The nearest standard value for R_{a2} is 402k Ω .

R_{a3} needs to be adjusted by V_{GSX} / V_{2W} to maintain the same feedback for impedance matching Equation 30.

$$R_{a3} = (200k\Omega)(1.0) = 200k\Omega \quad (\text{EQ. 30})$$

The closest standard value is for R_{a3} is 200k Ω .

The gain through the TCM38C17 (PCMIN to PWRO+) is given in Equation 31.

$$G_{(\text{PCMIN-PWRO})} = \frac{R_1 + R_2}{4 \left(R_2 + \frac{R_1}{4} \right)} \quad (\text{EQ. 31})$$

The input and output gain adjustments are discussed in detail in PCM CODEC / Filter Combo Family: Device Design-in and Application Data [1]. The maximum output (Gain = 1) can be obtained by maximizing R1 and minimizing R2 (Figure 3). This can be done by letting R1= infinity and R2 = 0, as shown in Figure 6.

Transhybrid Balance ($Z_L = 600\Omega$)

The internal GSX amplifier of the TCM38C17 is used to perform the transhybrid balance function. Equation 27, repeated here in Equation 32, is used to determine the value of R_{a5} for proper transhybrid balance.

$$R_{a5} = V_{PWRO} \left(\frac{R_{a2}}{V_{TX}} \right) = \frac{R_{a2} Z_L}{400} \quad (\text{EQ. 32})$$

The values of R_{a2} , R_{a5} , and R_{ZO1} should be scaled by 1000 to minimize loading of the GSX amplifier.

V_{TX} is equal to $(0.7745V_{RMS})(2/3)$. V_{PWRO-} is equal to $0.7745V_{RMS}$.

$$R_{a5} = \frac{R_{a2} Z_L}{400} = \frac{402K\Omega \times 600\Omega}{400\Omega} = 603k\Omega \quad (\text{EQ. 33})$$

Closest standard value for R_{a5} is 603k Ω .

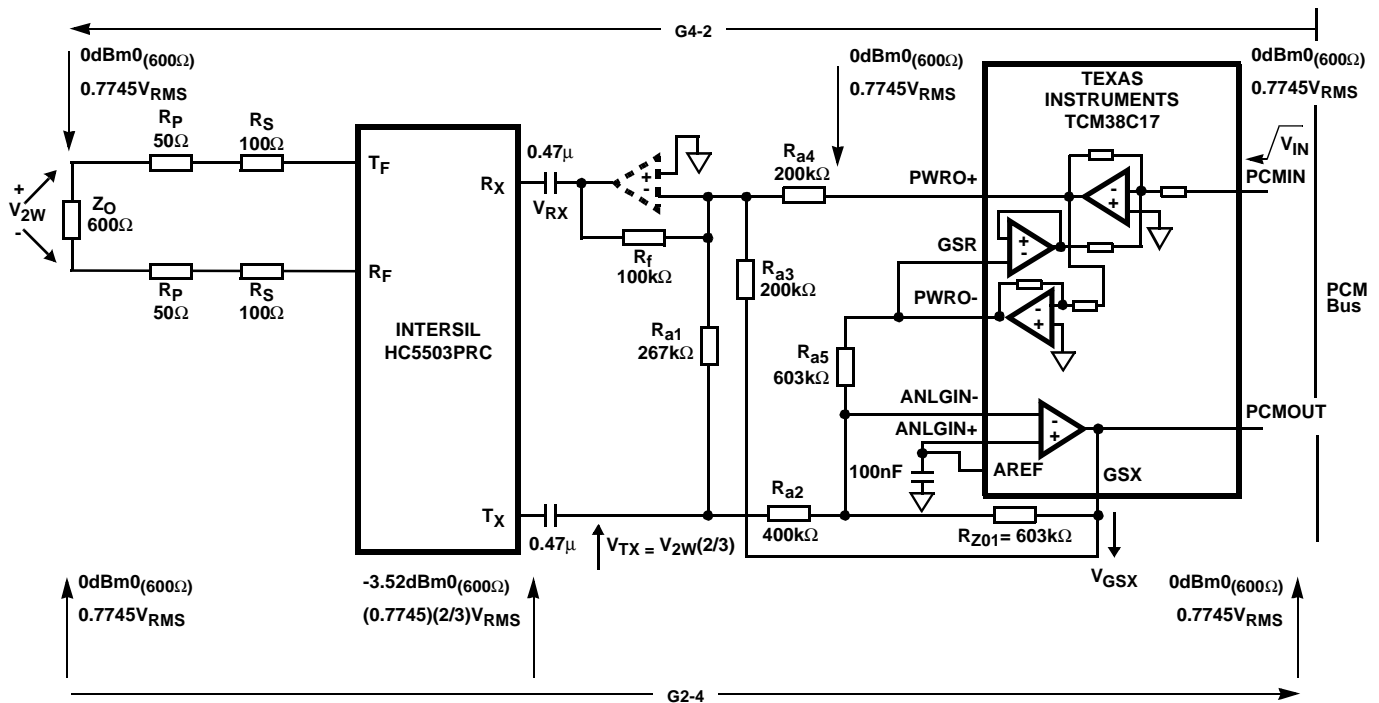

FIGURE 6. REFERENCE DESIGN OF THE HC5503PRC AND THE TCM38C17 WITH A 600 Ω LOAD IMPEDANCE

Specific Implementation for China

The design criteria for a China specific solution are as follows:

- Desired line circuit impedance is $200 + 680/j0.1\mu\text{F}$
- Receive gain (V_{2W}/V_{PCMIN}) is -3.5dB
- Transmit gain (V_{PCMOUT}/V_{2W}) is 0dB
- 0dBm0 is defined as 1mW into the complex impedance at 1020Hz
- $R_p = 50$, $R_s = 100$

Figure 7 gives the reference design using the Intersil HC5503PRC SLIC and the Texas Instruments TCM38C17 Quad Combo. Also shown in Figure 7 are the voltage levels at specific points in the circuit. These voltages will be used to adjust the gains of the network.

Adjustment to Get -3.5dBm0 at The Load Referenced to 600Ω

The voltage equivalent to 0dBm0 into 811Ω ($0\text{dBm0}_{(811\Omega)}$) is calculated using Equation 36. China complex load at 1kHz is equal to 811Ω.

$$0\text{dBm}_{(811\Omega)} = 10\log\frac{V^2}{811(0.001)} = 0.90055V_{\text{RMS}} \quad (\text{EQ. 34})$$

The gain referenced back to $0\text{dBm0}_{(600\Omega)}$ is equal to:

$$\text{GAIN} = 20\log\frac{0.90055V_{\text{RMS}}}{0.7745V_{\text{RMS}}} = 1.309\text{dB} \quad (\text{EQ. 35})$$

The adjustment to get -3.5dBm0 at the load referenced to 600Ω is:

$$\text{Adjustment} = -3.5\text{dBm0} + 1.309\text{dBm0} = -2.19\text{dB} \quad (\text{EQ. 36})$$

The voltage at the load (referenced to 600Ω) is given in Equation 39:

$$-2.19\text{dBm}_{(600\Omega)} = 10\log\frac{V^2}{600(0.001)} = 0.60196V_{\text{RMS}} \quad (\text{EQ. 37})$$

Impedance Matching

For impedance matching of the 2-wire side we set the input voltage at PCMIN equal to zero. This effectively grounds the PWRO- input of the GSX amplifier. To determine the value of R_{a2} to achieve a 2-wire to 4-wire gain (V_{2W} to PCMOUT) of 0dB we use Equation 24, repeated in Equation 38.

$$V_{\text{GSX}} = 4R_s \frac{V_{2W}}{Z_0} \left(\frac{R_{Z01}}{R_{a2}} \right) \quad (\text{EQ. 38})$$

Substituting the required voltage levels (Figure 7) for V_{GSX} (0.51769) and V_{2W} (0.60196) and rearranging to solve for R_{a2} results in Equation 39. Where: $V_{\text{GSX}}/V_{2W} = 0.860$, and $Z_0 = R_{Z01}$:

$$R_{a2} = \frac{400}{0.860} = 465.1 \quad (\text{EQ. 39})$$

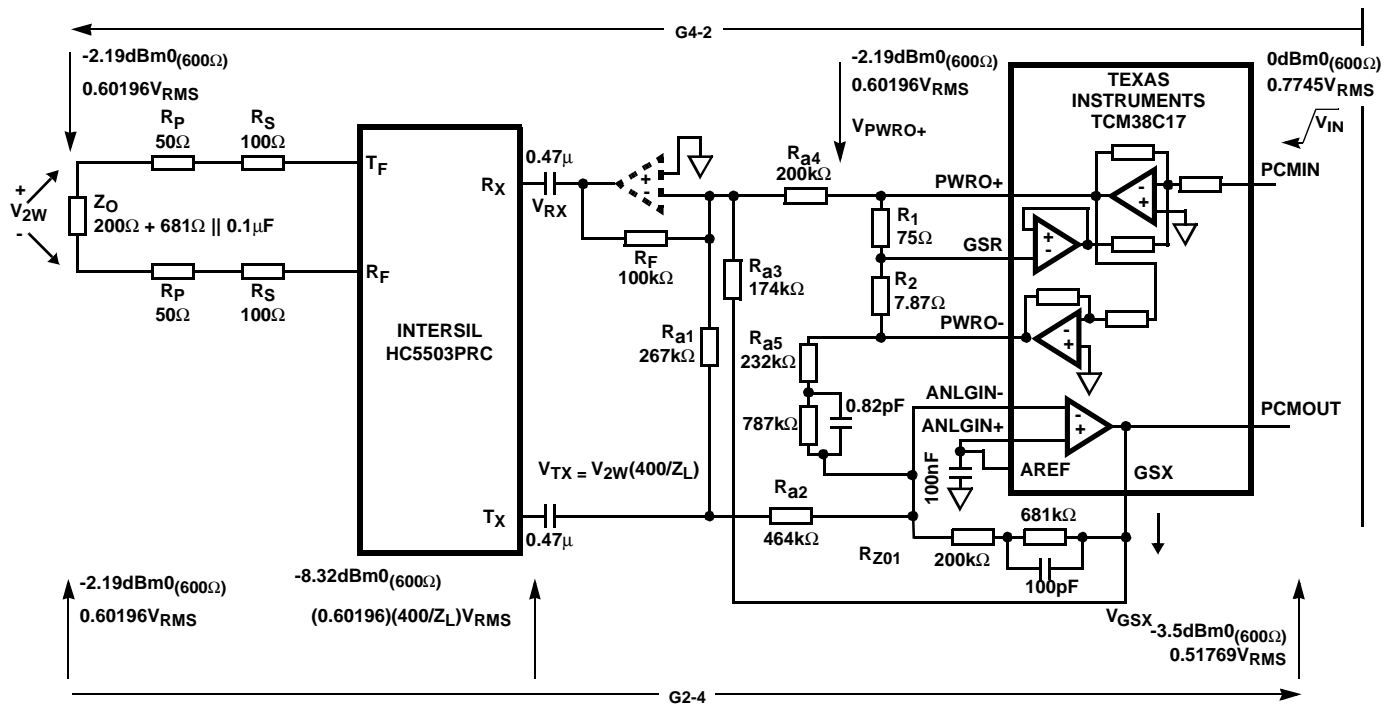

FIGURE 7. REFERENCE DESIGN OF THE HC5503PRC AND THE TCM38C17 WITH CHINA COMPLEX LOAD IMPEDANCE

The value of R_{a2} needs to be scaled by 1000 to minimize the effects on the GSX amplifier.

The nearest standard value for R_{a2} is 464k Ω .

R_{a3} needs to increase by (0.860) to maintain the same feedback for impedance matching Equation 40.

$$R_{a3} = (200\text{k}\Omega)(0.806) = 172\text{k}\Omega \quad (\text{EQ. 40})$$

The closest standard value is for R_{a3} is 174k Ω .

To achieve a 4-wire to 2-wire gain (PCMIN to V2W) that is equivalent to 0dBm(600 Ω) at the complex load, the gain through the TCM38C17 (PCMIN to PWRO+) must equal -2.19dBm (0.60196V_{RMS}) the gain is 0.777.

The gain through the TCM38C17 (PCMIN to PWRO+) is given in Equation 41.

$$G_{(\text{PCMIN-PWRO})} = \frac{R_1 + R_2}{4 \left(R_2 + \frac{R_1}{4} \right)} \quad (\text{EQ. 41})$$

Setting the gain in Equation 41 equal to 0.777 we can now determine the value of the gain setting resistors R_1 and R_2 . Selecting the value of R_1 to be 75k Ω , R_2 is calculated to 7.87k Ω . (Note: the value of $R_1 + R_2$ should be greater than 10k Ω but less than 100k Ω .)

$$0.777 = \frac{R_1 + R_2}{4 \left(R_2 + \frac{R_1}{4} \right)} \quad (\text{EQ. 42})$$

$$R_2 = R_1 \left(\frac{0.222}{2.108} \right) = 75\text{k}\Omega(0.105) = 7.87\text{k}\Omega \quad (\text{EQ. 43})$$

The closest standard value is for R_2 is 7.87k Ω .

Transhybrid Balance ($Z_L = 200 + 680/j0.1\mu\text{F}$)

The internal GSX amplifier of the TCM38C17 is used to perform the transhybrid balance function. Equation 27, repeated here in Equation 44, is used to determine the value of R_{a5} for proper transhybrid balance.

$$R_{a5} = V_{\text{PWRO-}} \left(\frac{R_{a2}}{V_{\text{TX}}} \right) = \frac{R_{a2} Z_L}{400} \quad (\text{EQ. 44})$$

V_{TX} is equal to (0.60196V_{RMS})(400/ Z_L). $V_{\text{PWRO-}}$ is equal to 0.60196V_{RMS}.

$$R_{a5} = \frac{R_{a2} Z_L}{400} = \frac{464\text{K}\Omega \times 200\Omega + 680\Omega j10.1\mu\text{F}}{400\Omega} \quad (\text{EQ. 45})$$

Closest standard values, $R_{a5} = 232\text{k}\Omega + 787\text{k}\Omega \parallel 82\text{pF}$

The values of R_{a2} , R_{a5} , and R_{ZO1} should be scaled by 1000 to minimize loading of the GSX amplifier. Scaling of a complex load is shown in Equation 46.

$$R_{ZO1} \quad \text{or} \quad R_{ZO2} = 100(\text{Resistive}) + \frac{\text{Reactive}}{100} \quad (\text{EQ. 46})$$

Note: When matching a complex impedance some impedance models (900+2.15 μF , $K = 100$) will cause the op amp feedback to be open at DC currents, bringing the op amp to an output rail. A resistor with a value of about 10 times the reactance of the capacitor (21.6nF) at the low frequency of interest (200Hz for example) can be placed in parallel with the capacitor in order to solve the problem (368k Ω for a 21.6nF capacitor).

Reference

[1] Website

www.ti.com/sc/docs/psheets/abstract/apps/slwa006.htm

All Intersil products are manufactured, assembled and tested utilizing ISO9000 quality systems.

Intersil Corporation's quality certifications can be viewed at website www.intersil.com/design/quality

Intersil products are sold by description only. Intersil Corporation reserves the right to make changes in circuit design and/or specifications at any time without notice. Accordingly, the reader is cautioned to verify that data sheets are current before placing orders. Information furnished by Intersil is believed to be accurate and reliable. However, no responsibility is assumed by Intersil or its subsidiaries for its use; nor for any infringements of patents or other rights of third parties which may result from its use. No license is granted by implication or otherwise under any patent or patent rights of Intersil or its subsidiaries.

For information regarding Intersil Corporation and its products, see web site www.intersil.com

Sales Office Headquarters

NORTH AMERICA

Intersil Corporation
2401 Palm Bay Road
Palm Bay, FL 32905
TEL: (321) 724-7000
FAX: (321) 724-7240

EUROPE

Intersil SA
Mercure Center
100, Rue de la Fusee
1130 Brussels, Belgium
TEL: (32) 2.724.2111
FAX: (32) 2.724.22.05

ASIA

Intersil Ltd.
8F-2, 96, Sec. 1, Chien-kuo North,
Taipei, Taiwan 104
Republic of China
TEL: 886-2-2515-8508
FAX: 886-2-2515-8369